

## Lessons Learned from a 400kV Busbar Misoperation Utilizing the IEC 61850 Standard

Dhanabal Mani, Vijay Shanmugasundaram, *IEEE Member* and Jason Buneo, *IEEE Member*

**Abstract--** The implementation of IEC 61850 standard for substation design and commissioning is fast-phased method of defining grid protection schemes throughout the world. The protection logic that involves dc control circuits are executed internally in the Intelligent Electronic Devices (IEDs) and effectively communicated between the IEDs via Generic Object Oriented Substation Events (GOOSE). Any error in the mapping of GOOSE signals will result in undesired operation of the protection schemes.

The main buses in power substations are designed to carry load currents through the individual feeders as well as high amplitude currents during bus fault conditions. Any delay in fault isolation or improper relay operation could result in severe damage to the substation buses, and the equipment connected to them. Therefore, proper design and testing of the bus-bar protection scheme is required to ensure safe and reliable operation of the substation. The complex protection schemes, such as bus-bar and breaker failure protection are relatively easier to design using the modern IEC 61850 standard. However, the implementation of these schemes in the real world poses certain unique challenges.

This paper discusses the investigation of the tripping of a 400kV substation due to improper operation of a bus-bar protection scheme. This incident happened when a Zone 2 fault occurred on one of the 400kV line feeders, immediately triggering a breaker-failure condition. Under a normal trip scenario, the zone 2 timer will time out and the line IED will issue a trip signal to the line breaker to isolate the fault. The line IED will also then issue a Breaker-Failure Initiate (BFI) signal to bus-bar IEDs through GOOSE messages. The breaker-failure condition is only declared when the line breaker fails to trip within a specified breaker-failure time. However, in this case, the breaker-failure condition was initiated before the Zone 2 timer expired instead of after.

An investigation was carried out to determine the reason for declaring a breaker-failure condition even before zone 2 tripping of the line IED. Further analysis of the IEC 61850 network and GOOSE configurations led to the conclusion that the BFI signal was mapped incorrectly. The bus-bar IEDs were configured to receive a BFI signal through GOOSE messaging for a fault pick-up signal instead of a fault trip signal by protection IEDs. This minor error caused the entire substation to be out of service. This paper discusses the methods of testing so that would help prevent this situation.

### I. INTRODUCTION

The protection schemes utilized in substations are implemented through protective relays from various

manufacturers. Legacy systems that use electro-mechanical relays share critical information such as breaker status, interlock signals, etc. through a network of copper wires that are monitored by some control center. With the advent of Intelligent Electronic Devices (IEDs), data sharing between protective relays and control centers has become possible by using Ethernet and fiber optic cables. This has reduced the amount of copper necessary in substations, making them cheaper to produce and maintain. However, the inter-operability between different relay manufacturers became increasingly difficult, as many IED manufacturers adopted proprietary standards for data representation and interpretation. In 2005, a common standard was first published by a shared effort from IEC 60870-5-101, -103, -104 and, Utility Communication Architecture 2.0 (UCA 2.0), and called IEC-61850.

The IEC-61850 standard allowed direct communication between IEDs from multiple vendors in a substation. The IEDs in a substation followed an abstract model for data definition which could be interpreted by all the compliant manufacturers. A Local Area Network (LAN) switch connected between IEDs passed the data in the form of Generic Object Oriented Substation Events (GOOSE) messages. These messages contain essential information such as control signals and acknowledgements. The implementation of IEC-61850 standard through LAN based architecture considerably increased reliability and speed of peer-to-peer communication. Also, a complex protection scheme could be implemented easily through the LAN based design without increasing the complexity of physical wiring.

A protection scheme is implemented by configuring the IEDs to send or receive GOOSE messages from other substation equipment. Depending upon the complexity of the protection scheme being implemented, a GOOSE message could pass through a number of switches until the destination IED is reached. After analyzing the received message, further actions are carried out by the destination IED. A redundant network in LAN design prevents data loss by re-routing the path taken by the messages. Numerous network topologies are adopted to maintain an un-interrupted data flow from the source IED to the destination IED.

An IED in the substation can send or receive GOOSE messages to or from many different IEDs in the network. The proper mapping of GOOSE messages between IEDs is essential for execution of a protection scheme. The number of signals mapped depends on the number of IEDs and the elements of the protection scheme being implemented in the substation. The IEC 61850 standard ensures that the control functions and message flags seen on the communication network will be the same no matter which manufacturer device is used. However, mapping the IED's internal logic to the IEC 61850 standard can be tricky and great attention to detail must be maintained.

A. The System

A newly constructed 400kV IEC 61850 substation was fully commissioned prior to the work on this paper. It consists of 6 D-configuration systems, referred to as DIA by the customer, and is provided with a distributed busbar protection scheme as per "Fig.1". A D-configuration system has 3 circuit breakers with two outgoing circuits, one circuit is for line and the other circuit is for transformer or bus reactor. Both circuits could be lines as well. For circuit breaker maintenance of any line, the load gets transferred automatically from one bus to the other bus. No changeover of the line from one bus to another is required. For any bus fault conditions or scheduled maintenance, all interconnections will be on the healthy bus and no disturbance will come to the other circuits. Even if both buses become dead, circuits can still be in service through the tie circuit breaker. This is very advantageous in maintaining system stability.

400kV Substation with One and Half Breaker System

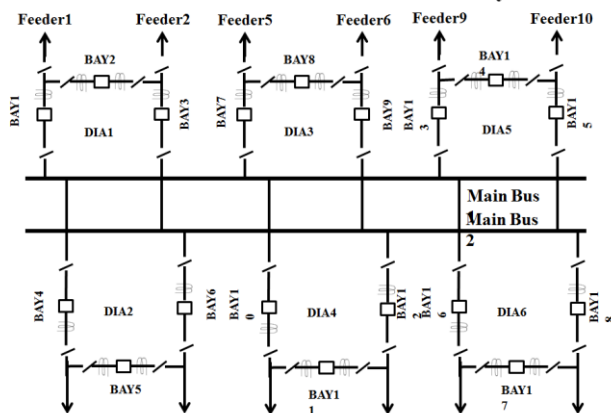

Fig. 1. 400kV Substation One-line Diagram

The IEC61850 based Substation Automation System (SAS) architecture used in this substation is shown in "Fig. 2". This architecture is defined in two levels as station level and bay level. A redundant PC based Human-to-Machine Interface (HMI) is used to control substation at station level, which supports communication over IEC 61850-8-1 bus as an IEC 61850 client. An IEC 61850-8-1 inter bay bus provides station to bay and bay to station exchanges. In this case, an Ethernet LAN is set up with ring configuration to maintain reliability, availability, and interoperability requirements of the system. Redundant gateways are used to exchange the information to remote network control centers using IEC 60870-5-101 protocol.

The bay level system consists of all circuit breakers, current and potential transformers, power transformers, and protective relays. IEDs in the bay level perform all function like control, monitoring and protection. The data exchange between bay level and station level happens with fibre optic ring connection according to IEC 61850-8-1 protocol..

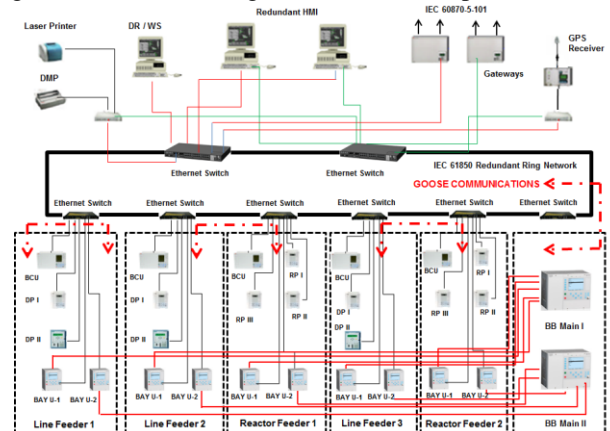

Fig. 2. Bay and Station Level IEC 61850 Communication Architecture.

This busbar protection scheme is implemented for Main Bus I and Main Bus II. All bay control units are connected with fiber optic cable to its main busbar relay for transmitting each bay's load current values, isolator and breaker statuses. An equivalent single line diagram of the substation is configured in the busbar main IEDs for proper replication of substation and for ensuring correct decision making in the protective scheme. In the case of a bus fault or breaker failure condition, the main busbar IED's make the decision to isolate the faulty feeders by sending a trip command to the bay IED's and in turn, the bay IED's trip the respective bay circuit breakers. This data sharing occurs within the busbar protection relay network and also these trip signals are sent as GOOSE messages over the IEC 61850 bus.

## II. IED ENGINEERING AND SYSTEM LEVEL ENGINEERING

The IED engineering process involves configuring the protection functions, interlock logic, metering functions, etc. in each of the IEDs. This process is shown in “Fig. 3”. The IED Configuration Description (ICD) file is then exported from each IEDs,into the Substation Configuration Language (SCL) file. The SCL output contains the IED’s capabilities (logical devices, logical nodes). It also reports the control blocks available in the ICD files that are used as inputs in the system level engineering design. Configuration tools are used to set up the communication between various devices. The transmission of the data sets is decided by the report control blocks. Also, GOOSE messages are configured in system level engineering tool with GOOSE control blocks [1].

### 400kV IEC61850 Substation Engineering and Commissioning

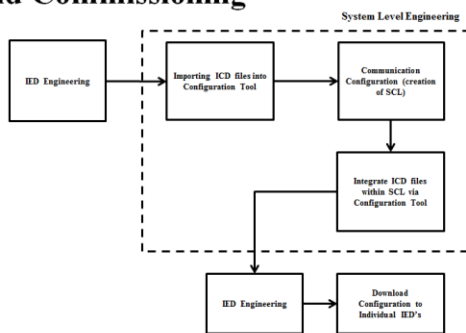

Engineering process for configuring IEDs in a GOOSE enabled substation

Fig. 3.Engineering Process for Configuring IEDs in a GOOSE Enabled Substation.

Ethernet switch configurations are then defined and downloaded into the switches.In this IEC 61850 network, GOOSE messages have priority over other messages, so Ethernet switches are necessary to support IEEE 802.1P standard for priority tagging.Finally, once the system level engineering is completed, the SCL file is re-imported back into IEDs, where all the configured GOOSE inputs that are coming from other IEDs are connected to the correct functions. Once the configuration is downloaded to the individual IEDs, the complete system architecture is defined [1].

Using the isolator logic, the busbar relay is capable of identifying and isolating respective feeders connectd with the faulty bus. Also, this busbar scheme is combined withbreaker failure protection. Any protection trip of respective bay protection IEDs will send a trip signal to respective busbar bay IEDs to initiate the breaker failure

protection as per “Fig.4”. If breaker fails to trip, this action will cause a breaker failure protection trip with BFI initiation and timer timeout. In IEC 61850 substations,a BFI signal may be configured as a GOOSE message from the protection IEDs to the breaker failure protection relays.The busbar IED will trip all feeders connected with the bus of the faulty feeder. Fault selection is processed by the busbar main protection IED with isolator staus[1].

### Breaker Failure Operation Logic IEC 61850 Substation : Normal

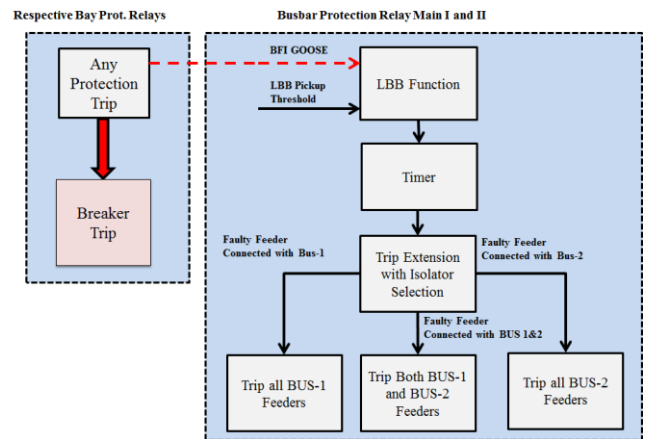

Fig. 4.Breaker Failure Scheme Operation Logic.

## III. 400kV SUBSTATION COMMISSIONING

During commissioning of the substation, the protection IED’s opertaion, busbar protection, and all other trip logic was verified to be in proper working order. Later an additional bay was added to the existing system. All of the protection schemes associated with the new bay were verified as well.

After successful commissioning of the new bay, a feeder was connected with Bus-I, there was a zone 2 line fault on the newly added 400kV line. Both Main I and Main-II distance protection relays in the substation sensed the fault correctly on Zone2 and started the Zone 2 timer. The Zone 2 trip timer is set for 300ms. It wasobserved that the busbar protection relay operated within 200ms for this faultand tripped the feeders connected with Bus-I and Bus-II.It caused the entire 400kV substation to be taken out of service.

After careful physical inspection of the substation and busbar protection relays, it was identified that there was no real bus fault and the busbar relay had misoperated due to thebreaker failure protection. The breaker failure initiate (BFI) signal was sent to the busbar IEDs through a GOOSE signal. After careful analysis of the IED GOOSE

configuration, it was found that the newly added bay had distance protection GOOSE messages configured with a start signal for breaker failure initiation instead of a trip signal. Since the breaker failure initiation started the function block timer with a start input, its timer operated within 150ms instead of waiting for the 300 ms Zone 2 timer to expire first. This caused the breaker failure to trip before the Zone 2 timer. Due to this small mistake, both the Main-I and Main-II protection operated and it led to an entire substation blackout. The erroneous logic is shown in “Fig. 5”.

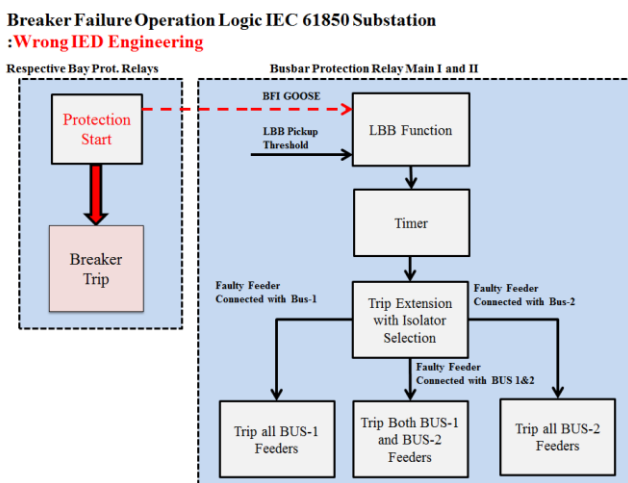

Fig. 5. Breaker Failure Scheme Operation Logic with Improper Configuration.

Figures 6 and 7 show the signal configuration of the GOOSE assignment for the breaker failure initiation sent to busbar protection IEDs. This signal configuration is defined in the IED level engineering and in the main line protection IEDs. “Fig. 6,” shows simulation example of the wrong GOOSE configuration for breaker failure initiation. In this case, the zone2 start signal has been assigned to breaker failure protection initiation as a GOOSE output. Whenever a zone 2 fault occurs, the zone2 start signal will send a breaker failure initiation and cause a breaker failure trip before the Zone 2 timer completes, and clears the fault. “Fig. 7,” shows the simulation example of the corrected GOOSE configuration for breaker failure initiation. In this scenario, if there is a zone 2 fault, the breaker failure protection will not send any GOOSE signal to the busbar IEDs from the main protection IEDs to initiate the breaker failure trip. The IED will send a GOOSE signal to the busbar IEDs only when there is a trip issued by the protection IEDs.

Fig. 6. Example of Incorrect IED GOOSE Configuration

Fig. 7. Example of correct IED GOOSE configuration

It is necessary to test the IED’s protection schemes and GOOSE signals properly, before commissioning the IEC 61850 substation or adding additional bays in the existing IEC 61850 substations. It is fairly easy to verify copper wire schemes for breaker failure protection schemes or any other protection schemes in conventional substation, when we require adding additional bays into service. In the case of IEC 61850 substations, it requires special care. We can use GOOSE monitoring software for testing an IED’s GOOSE configurations before putting IEDs and bays into service. Importing the SCL file of the IED under test into the GOOSE monitoring software can assist in verifying the GOOSE signals as required.

“Fig. 8,” shows one of the trip GOOSE signals from a distance protection IED. The purple font in this particular dataset, indicates the non-operation of the distance function and that its signal status is low. This means that this GOOSE signal will be seen by other relays in the substation as non-operative.

Fig. 8. GOOSE Monitoring, No-operation of Protection Function

“Fig. 9,” provides an example where the GOOSE signal color is Red. It indicates that this signal is high and that the protection function has operated. So this GOOSE will register when the distance protection trip goes high. The mapped IEDs which use this GOOSE signal will process and operate accordingly.

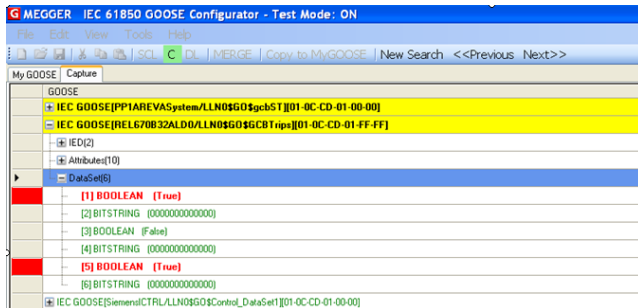

Fig. 9. GOOSE Monitoring, Operation of Protection Function.

With reference to “Fig. 8 and 9”, any GOOSE used in protection schemes can be tested, and verified without any risk of misoperation of the relays, and unwanted interruption of the substations. The breaker failure initiate (BFI) GOOSE signals have been corrected from a start signal to a trip and downloaded to the distance protection IEDs. Since there is no change in datasets, it is not required to update the system level engineering in the substation level as per “Fig.3”. Necessary validation of signal mapping and GOOSE configuration in line with substation configuration is required in any IEC 61850 substation when adding new bay/feeders into the existing substation.

#### IV. CONCLUSION

IEC 61850 substations are increasing widely throughout the world. Necessary testing procedures shall be required to follow the commissioning of those stations for proper operation, like one of the methods discussed in the paper to validate IEC 61850 GOOSE mappings. More challenges lie ahead in IEC 61850 substations especially when adding additional bays into service within existing IEC 61850 substations. As always additional care is required at the commissioning stage for any substation.

#### V. REFERENCES

[1]. *First Experiences with Design and Engineering of IEC 61850 Based Substation Automation Systems in India*, Rajiv Krishnan, Bapuji Palki, CEPSI 2006 Conference, Mumbai, India, November 6-10, 2006.

#### VI. BIOGRAPHY

**Dhanabal Mani** received his Bachelor of Electrical and Electronics Engineering from Bharathiyar University, India, in 2001. He commissioned the first 400kV IEC61850 substation in India in Madhya Pradesh as a lead commissioning engineer of the Substation Automation Group at ABB India Ltd. He has also developed custom relay applications as a R&D engineer at ABB Ltd, Sweden. Dhanabal joined Megger India as an Application Manager in August 2009 and is presently based in Megger, Dallas. He has over 13 years of field experience in protective relaying and commissioning, and has published numerous articles and presented at various international conferences on the subject.

**Vijay Shanmugasundaram** received his Bachelor of Technology with distinction in Electrical and Electronics Engineering from Amrita University, India, in 2008. He joined the Defense Research and Development Organization (DRDO) of India as a junior research fellow, specializing in the performance optimization of induction motors. In 2011, Vijay received his Master of Science in Electrical Engineering focusing on power systems from North Carolina State University. As a part of Master programme, he worked on IEC61850 substation development in Siemens Energy and Automation department. Vijay joined Megger as an Applications Engineer in December 2012 and is currently working on developing IEC61850 applications. He is an active member of IEEE and EPRI, participating in conferences and contributing to the working groups.

**Jason Buneo** received his B.S and M.S in Electrical Engineering from the University at Buffalo. In 2005 he joined GE Energy Services as a Field Service Engineer. He specialized in arc flash coordination studies, protective relay testing and calibration, and low/medium voltage switchgear repair. In 2008 he joined Megger as an Applications Engineer where he assisted Megger's customer base in their relay testing needs. He became the Applications Development Manager in 2012 where he now specializes in developing automated testing applications for protective relays. Jason continues to work closely with utility and industrial customers to develop new testing solutions. Jason has published several technical papers in industry journals and conferences. He is also active in the IEEE Power Systems Relaying Committee.